



WR 870 Battery
WR 870 Battery PRO



WR 870 Honda
WR 870 Honda PRO

strong
efficiently
user-friendly

Operating instruction



Table of contents

1	EC Declaration of Conformity.....	5
2	Legal information.....	7
3	Important basic information	8
	3.1 Scope of supply	8
	3.2 Conventions.....	9
	3.2.1 Symbols and signal words.....	9
	3.2.2 Pictogram overview.....	10
	3.3 Marking on the machine	11
	3.3.1 Warning pictogram on the machine	11
	3.4 Ordering spare parts	12
4	Safety.....	13
	4.1 Intended use of the machine	13
	4.2 Machine naming information.....	13
	4.3 Requirements for the operator	14
	4.4 Danger area.....	15
	4.5 Foreseeable misuse	
	Reasonably foreseeable misuse	16
	4.6 Behaviour in case of emergency.....	16
	4.6.1 Personal injury	16
	4.6.2 Case of fire.....	16
	4.6.3 Technical complications	16
	4.7 Application.....	17
	4.7.1 Local requirements	17
	4.7.2 Disposal.....	17
	4.8 Responsibility of the operator	17
	4.8.1 Obligations of the operator	18
	4.9 Personal responsibility	19
	4.10 Observance of the operating manual	20
	4.11 Residual hazards and protective measures.....	20
	4.12 Safety marking on the machine	20
	4.13 Personal protection	21
5	Safety instructions for the operator/user	22
6	Technical specifications.....	23
	6.1 General technical data WR 870.....	23
	6.2 General technical data WR 870.....	24
7	Assembly, first start-up	25
	7.1 Safety.....	25
	7.2 Assembly.....	25
	7.3 First start-up	25
8	Product description.....	26
	8.1 Battery WR 870 rechargeable battery	27
	8.1.1 Charge cycle	23
	8.1.2 Connecting the machine	27
9	Start-up	28
	9.1 Adjusting the handle height.....	28
	9.1.1 Adjustment process.....	28

Table of contents

9.2 Adjusting the brush.....	28
9.3 Starting the engine WR 870 Honda Pro.....	29
9.3.1 Opening the fuel valve	29
9.3.2 Cold start.....	30
9.3.3 Starting at operating temperature	30
9.3.4 Starter cord	30
9.3.5 After the cold start	30
9.4 Sweeping direction determine WR 870 Honda Pro	31
9.5 Stopping the engine WR 870 Honda Pro.....	32
9.6 Charging the WR 870 Battery	33
9.6.1 Blown fuse	33
9.7 Starting the WR 870 Battery Pro	34
10 Operation.....	35
10.1 Operation description	35
10.2 Service interval	35
11 Attachment.....	36
11.1 Attachment of the windrow maker	37
11.2 Transport position of windrow maker	38
12 Maintenance and servicing	39
12.1 General	39
12.2 Engine WR 870 Honda	40
12.3 Cleaning	40
12.4 Lubrication	40
12.5 Exchange of the brush element	41
12.5.1 Removal and installation of the brush element	41
12.6 V-belt replacement V-belt tightening.....	42
12.6.1 Replacement of change-of-direction belt WR 870 Honda	43
12.6.2 The anti-clockwise V-belt / timing belt (internal combustion engine only)	43
12.6.3 The V-belt rotating clockwise (only internal combustion engine)	44
12.7 Screw connections	45
12.8 Fuse replacement	45
12.9 Procedures after maintenance	46
12.10 Notes regarding maintenance work.....	46
12.11 Documentary list.....	46
13 Residual risks.....	47
14 Storage conditions.....	50
15 Cleaning.....	51
16 Troubleshooting.....	52
16.1 WR 870 Honda PRO	52
16.2 WR 870 Battery PRO	53
17 Decommissioning	54
17.1 Decommissioning	54
17.2 Dismantling / Disposal.....	54
18 Warranty policy.....	55

Table of contents

19 Spare parts list.....	54
19.1 WR 870 Honda PRO	58
19.2 Base frame WR 870 Hond PRO	60
19.3 Support wheel with spindle WR 870 Honda PRO	61
19.4 Push handle WR 870 Honda PRO.....	62
19.5 Control lever WR 870 Honda PRO	63
19.6 Guide pulley WR 870 Honda PRO	64
19.7 Tensioner WR 870 Honda PRO	65
19.8 Drive shaft assembly WR 870 Honda PRO	65
19.9 brush WR 870 Honda PRO.....	66
19.10 WR 870 Akku PRO	68
19.11 Support wheel WR 870 Akku PRO.....	70
19.12 Brush WR 870 Akku PRO.....	73
20 Plans and other information	74
20.1 Current-flow plan	74
21 List of figures.....	75

1 EC Declaration of Conformity

EC declaration of conformity in accordance with Machinery Directive 2006/42/EC Annex II 1.A

The manufacturer / distributor:

Westermann GmbH & Co. KG
Schützenhof 23
D - 49716 Meppen

hereby declares that the following product

Product name: WR 870 Battery |

Make: Westermann GmbH & Co. KG

Serial number: _ _ . _ _ _ _

Model / type description: WR 870

Description: The Westermann Radial Sweeper is built exclusively for the general sweeping of hard surfaces such as yards, roads, parking lots, silo slabs and stables. Any other use is considered improper. The manufacturer is not liable for damage resulting therefrom. The risk is borne by the user alone.

Proper use also includes compliance with the operating, maintenance and service conditions prescribed by the manufacturer.

The following additional EU directives have been applied:

The protection objectives of the following EC Directive are complied with.

Machinery Directive 2006/42/EC

EMC Directive 2014/30/EU

Low Voltage Directive 2014/35/EU

1 EC Declaration of Conformity

The following harmonised standards were applied:

EN ISO 12100:2010 Safety of machinery - General principles for design - Risk assessment and risk reduction (ISO 12100:2010)

The following other technical specifications were applied:

Name and address of the person authorised to compile the technical documentation:

Westermann GmbH & CO. KG
Mr Alfons Westermann Tel.: 05931 | 496 90 0
Schützenhof 23 E-Mail: info@westermann-radialbesen.de
49716 Meppen URL: www.westermann-radialbesen.de

Location: 49716 Meppen
Date: 19.01.2017

(Signature)

Alfons Westermann Managing Director

2 Legal information

Issuer: Westermann GmbH & Co.KG

Publisher:

Westermann GmbH & CO. KG

Mr Alfons Westermann

Phone: +49 (0) 5931 | 496 90 0

Schützenhof 23

Fax: +49 (0) 5931 | 496 90 99

49716 Meppen

E-Mail: info@westermann-radialbesen.de

Internet: <http://www.westermann-radialbesen.de>

Managing Director: Alfons Westermann

Form of organisation: Limited partnership

Location: 49716 Meppen

Commercial Register Osnabrück, HRA 100274

Personally liable partner:

Westermann Beteiligungs-GmbH,

HRB Osnabrück no. 100562,

UST-ID no.: 193643718,

Copyright notice:

The contents of this document are protected by copyright under German copyright law and international treaties.

All copyrights to the contents of this document are owned by UPAS GmbH unless and to the extent that another author is expressly indicated or obviously recognisable.

The user is not granted or reserved any industrial property rights, rights of use or other rights by the provision of the contents. The user is prohibited from registering rights of any kind for the know-how or parts thereof.

The passing on, transfer and other dissemination of the contents of this document to third parties, the making of copies, duplicates and other reproductions as well as the utilization and other use - even in part - are prohibited without the prior, express and written consent of the author, unless and insofar as mandatory statutory provisions permit such use.

Infringements against copyright are illegal, according to §§ 106 ff. Copyright Act and grant the holders of copyrights claims for injunctive relief and damages.

Subject to change:

The Westermann GmbH & Co. KG reserves the right to change this document and the subject matter described therein at any time without prior notice, in particular to improve and expand it, provided and insofar as contractual agreements or legal requirements do not conflict with this.

3 Important basic information

3.1 Scope of supply

The operating manual is part of the working equipment and must be kept accessible in the immediate vicinity of the machine at all times.

The operating manual contains important information for safe and effective operation of the machine. Therefore, the operator must read and understand this operating manual carefully.

The basic requirement for safe working is compliance with all safety instructions and operating procedures given in this operating manual. The local accident prevention regulations and general safety regulations for the specific application must also be observed.

The provided supplier documentation for the installed components must also be observed.





The illustrations are provided for basic understanding and may deviate from the actual design.

The manufacturer assumes no liability for damage due to non-observance of the operating manual, improper use, improperly performed maintenance or repairs, unauthorised modifications, technical modifications and use of unauthorised spare parts.

3 Important basic information

3.2 Conventions







3.2.1 Symbols and signal words

Symbol / signal word	Meaning
	Indicates the handling and effects of the safety information.
	Alerts you to a dangerous situation that, if not avoided, <u>will</u> result in death or serious injury.
	Alerts you to a dangerous situation that, if not avoided, <u>may</u> result in death or serious injury.
	Alerts you to a dangerous situation that, if not avoided, may result in minor or moderate injury.
	Indicates possible damage to property and other important information.

3 Important basic information

3.2.2 Pictogram overview

The safety instructions contained in this operating manual, which can cause danger to persons and the machine if ignored, are specially marked with the following pictograms.

Pictogram	Importance
	General warning sign
	Falling hazard
	Automatic start-up hazard
	Opposing rollers hazard (Entanglement risk)
	Harmful or irritating substances hazard
	Toxic substances hazard
	Hand injuries hazard
	Hot surface hazard
	Crushing hazard
	Slip hazard
	Electrical voltage hazard
	Obstacles on the ground hazard

3 Important basic information

3.3 Marking on the machine

The Radial Sweeper WR 870 has a nameplate that contains all basic data. Components and accessories from suppliers have their own nameplates.

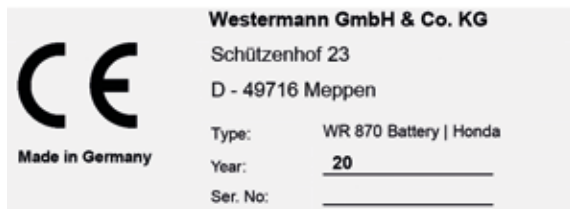

3.3.1 Warning pictogram on the machine



Article number: AUF-00-00016



Article number: AUF-00-000028

NOTICE

Labels must always be kept clean. Missing or damaged labels must be replaced.

3 Important basic information

3.4 Ordering spare parts

NOTICE

When ordering spare parts or accessories, state the type designation, machine number and year of manufacture. The use of accessories and spare parts from other manufacturers is only permitted after consultation with the manufacturer.

Original accessories and manufacturer-authorised accessories are provided for safety. Use of other accessories may void liability for consequential damages.

4.1 Intended use of the machine

The Westermann **Radial Sweeper WR 870** is to be used exclusively for the intended use described here. The Radial Sweeper WR 870 is a hand-guided machine. Areas of application of the working machine are the sweeping of hard surfaces such as yards, paths, parking lots, silo slabs and stables, clearing snow or similar work.

The **Radial Sweeper WR 870** only has the brush in its basic version. The approved attachments can be found under the accessories chapter.

Any use over and above this is considered improper. The manufacturer is not liable for damage resulting therefrom. The risk is borne by the user alone. Proper use also includes compliance with the operating, maintenance and service conditions prescribed by the manufacturer.

4.2 Machine naming information

The Radial Sweeper WR 870 Honda or Radial Sweeper WR 870 rechargeable battery is referred to below simply as the machine, Radial Sweeper or WR 870.

4.3 Requirements for the operator



Danger due to misuse!
Fehlgebrauch kann zu gefährlichen Situationen führen.

Deshalb:

- ✓ Refrain from any use beyond the intended use or different use.
- ✓ Strictly comply with all information in this operating manual and, where applicable, the associated documents.
- ✓ Switching operations on the controls can only be carried out by instructed persons.
- ✓ Maintenance and servicing must be carried out exclusively by trained maintenance personnel.
- ✓ Refrain from modifying, converting or altering the design or individual pieces of equipment with the aim of changing the area of application or usability.
- ✓ Only use the equipment with the aids specified in the operating manual.
- ✓ Only use the equipment in a technically perfect condition.
- ✓ Use in areas with an explosive atmosphere is prohibited.
- ✓ Do not exceed the carrying capacity of the equipment.
- ✓ Avoid transporting persons with the equipment.

NOTICE

Maintenance and repair
Maintenance and repair work is part of the intended use and must be carried out in compliance with the maintenance intervals.

4.4 Danger area



Danger while staying in the danger area!



Staying in the danger zone involves risks that unauthorised persons cannot assess.

Therefore:

- ✓ Always monitor the danger zone during the work process and ensure that no persons are present there.
- ✓ If an unauthorised person enters the danger zone, warn the person and stop operating immediately.

The area surrounding the machine with a safety distance of at least one meter is defined as a danger area. This area must be free of persons during the operation in order not to influence the work process and to cause hazards. Attachments and ejected debris can increase the danger area of the machine, depending on their size.



(Fig. 1 - Danger area)

4 Safety

4.5 Foreseeable misuse | Reasonably foreseeable misuse

All use deviating from the intended use is considered misuse and is not permitted.

These include, for example

- Transport of humans and animals
- Use as a climbing aid
- Use outside the permissible operating limits

4.6 Behaviour in case of emergency



4.6.1 Personal injury



If during use an event occurs from which personal injury results, the measures taken depend on the severity of the injury.

4.6.2 Case of fire



fire extinguisher

In the event of a fire, immediate action must be taken.

- Protect people
- Fight the fire
- Repair damage

4.6.3 Technical complications

If technical complications occur during use, they must be remedied by a specialist before further use.

4.7 Application

The area of application includes all locations worldwide that enable safe use of the machine. Use must be in accordance with the specified intended use.

4.7.1 Local requirements

The area of application includes all locations worldwide that enable safe use of the machine. To this end, the following criteria must be met.

- ✓ Safe installation of the machine
- ✓ Temperature range of -10°C to $+40^{\circ}\text{C}$
- ✓ Suitable area of use which guarantees the safe usage of the WR 870.

4.7.2 Disposal

For environmentally sound disposal, the hazardous substances must be disposed of separately. All other materials must be sorted according to their material quality and disposed of accordingly.

4.8 Responsibility of the operator

If the machine is used commercially, the operator is subject to the statutory provisions on occupational safety.

4.8.1 Obligations of the operator

The operator is responsible for ensuring the machine is good working order.

- ✓ The operator must regularly check all safety equipment for functionality and completeness.
- ✓ The operator must ensure that prescribed maintenance is carried out as scheduled.
- ✓ The operator must inform the manufacturer immediately of any damage detected.
- ✓ The operator must provide the personnel with the necessary protective equipment and check, maintain and replace defective parts in accordance with regulations.
- ✓ The operator must request a new copy of the instruction manual if it is in poor condition or parts are missing.
- ✓ The operator must immediately replace all labels, signs or stickers that are in poorly readable condition or have been lost.
- ✓ The operator must keep the workrooms and escape routes free and in good condition.

NOTICE

The WR 870 Battery and the WR 870 Battery PRO MUST, after EVERY use, be connected properly to the charging station again to avoid a deep discharge of the battery.

4.9 Personal responsibility

Basic requirements

- ✓ Only persons who are expected to observe the safety regulations and perform their work reliably may enter the danger zone.
- ✓ Persons whose ability to act is influenced by drugs, alcohol, medicines or the like are not permitted.
- ✓ When selecting personnel, the age and occupation-specific regulations applicable at the place of work must be observed.
- ✓ The user must be at least 16 years old!

Qualifications

In general, persons may only perform the activities for which they have the necessary qualifications.

Specialists for installation and start-up

Able to carry out the work entrusted and to independently recognize and avoid dangerous situations due to professional training, knowledge and experience as well as knowledge of the relevant provisions.

Service staff for maintenance and start-up

Able to carry out the work entrusted and to independently recognize and avoid possible danger due to professional training, knowledge and experience as well as knowledge of the relevant provisions.

Electrical specialist for maintenance, installation and start-up

Able to carry out the work and to independently recognize and avoid possible danger due to professional training, knowledge and experience as well as knowledge of the relevant standards and provisions. The electrical specialist is trained for the specific location in which he works and knows the relevant standards and regulations.

Instructed operating personnel for operation

Is informed of the tasks entrusted and possible dangers of improper conduct after instruction given by the operating company.

4.10 Observance of the operating manual



The operating manual is provided by the manufacturer or supplier of the product in order to provide the user with essential knowledge for the proper and safe use and to point out dangers in handling the machine.

Before starting up the machine, the operating manual must be worked through; it must be observed carefully during start-up. We point out that we accept no liability for damage and malfunctions resulting from non-compliance with the operating manual.

The illustrations and information contained in the operating manual are subject to technical modifications necessary for the improvement of the machine.

4.11 Residual hazards and protective measures

The knowledge and technical implementation of the safety instructions contained in this documentation is a prerequisite for a faultless product. However, this documentation cannot cover all the details of every conceivable case of machine use. Therefore, as in any other case, especially due to human error, there is a residual risk. This residual risk should be kept to a minimum by this documentation.

4.12 Safety marking on the machine

NOTICE

Danger and information points, as well as important information must be marked on the machine and, if necessary, due to dirt or if unrecognisable, cleaned or renewed.

4.13 Personal protection

The Personal Protective Equipment (PPE) is not included in the scope of delivery. Responsibility for the availability, testing and proper use of PPE therefore lies with the operator.

- ✓ Wear PPE according to the instructions below.
- ✓ Do not enter the danger area without PPE.
- ✓ On the equipment follow the attached instructions for PPE.



Wear foot protection

Protection of the feet from heavy falling parts, slip prevention, piercing of footwear by sharp-edged parts.



Wear protective clothing

Close-fitting workwear with low tear resistance, with tight sleeves and no protruding parts. Predominantly serves as protection from being drawn into rotating machine parts. When working on the electrical system, wear work clothing with arc protection.



Use hand protection

Protection of hands from friction, abrasions, punctures and cuts, as well as from contact with hot surfaces. When working on live parts, use insulated gloves.



Use hearing protection

Protection of hearing from damaging sound frequen-

If other persons are to operate the machine, they must be instructed in the operation of the machine and the operating manual must be read and understood in order to avoid accidents.

Before removing safety devices, for example a safety cover, make sure that all moving parts of the machine have come to a standstill. Removed parts must be re-attached after maintenance.

Pay attention to persons, animals, obstacles etc. in the vicinity of the machine before using the machine to avoid personal injury or material damage.

Never transport people on the machine or on attachments.

The surface to be swept must first be cleaned of larger foreign bodies. Even stones, wires, pieces of wood and the like can be ejected uncontrollably under certain circumstances by the Radial Sweeper.

Observe the marked hazard area specified in chapter 4.4 on page 11

NOTICE

Notes WR 870 Honda

Please never leave the machine unattended!

Familiarize yourself with the handling of the engine.
Remember how to turn off the engine in an emergency.

- ✓ Do not place any objects on the engine or allow any flammable liquids near.
- ✓ Do not tilt the sweeper more than 20°, otherwise petrol may leak.
- ✓ Keep feet and hands away from the rotating bristles.
- ✓ Due to the high temperatures of the internal combustion engine, you should take care that no persons or objects get near the hot engine.
- ✓ The exhaust becomes extremely hot during operation and does not cool down for some time after the engine has stopped. Do not touch the exhaust when it is hot. In order to avoid serious burns or a fire hazard, please allow the engine to cool down before transport or storage in a closed room!

6 Technical specificationsta

6.1 General technical data WR 870

Basic dimensions	WR 870 Battery	WR 870 Honda	Unit
Machine length	1,8	1,8	meters (m)
Machine length + swath plate:	2,3	2,3	meters (m)
Machine width	0,86	0,86	meters (m)
Working width	0,86	0,86	meters (m)
Machine height	0,45	0,66	meters (m)
Total height	1,00	1,00	meters (m)

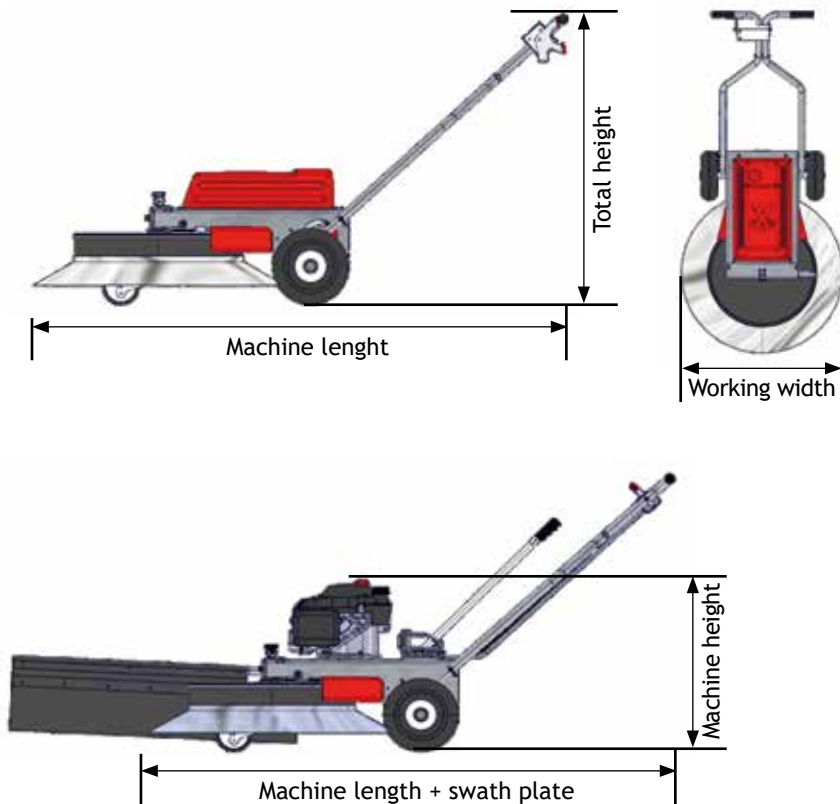

(Fig. 2 - Dimensions)

6 Technical specificationsta

6.2 General technical data WR 870

Technical specifications	WR 870 Battery	WR 870 Battery PRO	WR 870 Honda	WR 870 Honda PRO
Engine	12 V DC motor		Honda GCV 160 OHC Honda GXV 160	
Period of operation	up to 2,5 h/battery charge		continuous	
Handlebar	height adjustable		height adjustable	
Working width	about 870 mm		about 870 mm	
Direction of rotation	left right		left right	
Weight	75 kg		83 kg	
Tyres	260 / 85 pneumatic		260 / 85 pneumatic	
Guide wheel	125er solid rubber	160er solid rubber	125er solid rubber	160er solid rubber
Charger	Special charger with automatic shutoff		-	
Brush:	Polypropylene brush		Polypropylene brush wire PPN mixed stock wire brush	
Brush container height:	180 mm	230 mm	180 mm	230 mm
Area performance	2.500 m ² /h		2.500 m ² /h	



(Fig. 3 - Technical data)

7 Assembly, first start-up

7.1 Safety

NOTICE

To ensure the safety of man and machine easy and risk-minimised installation/handling was taken into consideration during construction. Thus, the handling machine is subject to all applicable DIN EN standards. Operator training and instruction are required and further reduce the safety risk.

7.2 Assembly

The complete assembly and first start-up is carried out exclusively by the manufacturer. The machines are subjected to a thorough test run and are supplied only after successful acceptance.

7.3 First start-up

NOTICE

Before first start-up, check the entire vehicle for possible damage.

The Westermann WR 870 is designed and implemented for the demanding user. It is possible to sweep hard surfaces such as yards, paths, parking lots, silo slabs, stables as well as snow.

The powerful battery or the 4-stroke petrol engine ensures effortless working with a high degree operational readiness.

Thanks to the rocker switch on the handrail or the Bowden cable on the base frame, the **WR 870 Battery** and **WR 870 Honda** are easy to operate and they allow maximum flexibility when setting the direction of rotation. Furthermore, it is possible by the arrangement of the three wheels to use the **WR 870** in almost every corner. Thanks to the brush angle any unevenness can be compensated for.

The hand-guided sweeper has a mechanical device that, as soon the front part is raised, automatically brings the sweeper into a resting position. The bristles are lifted off the ground.

To operate, simply push forward and this attachment folds down and the bristles are back in contact with the ground.

Not only the general safety instructions listed under the main item „Safety“ are to be observed, but also the special safety instructions inserted under the other main points.

The base frame consists of a robust, hot-dip galvanised torsion-free steel construction, making the **WR 870** ideal for use in the agricultural sector.

8 Product description

8.1 Battery WR 870 rechargeable battery

The machine has a battery with a voltage of 12 volts and 66 Ah.

8.1.1 Charge cycle

NOTICE

The machine **MUST**, after **EVERY** use be properly connected to the charging station again to prevent a deep discharge of the battery. Deep discharge of a battery begins when it falls below the discharge cut-off voltage. This is a set voltage up to which the battery may be discharged. Batteries of this type can undergo deep discharge even when not in use, solely due to self-discharge. The batteries used have a cycle lifetime of three times that of conventional batteries.

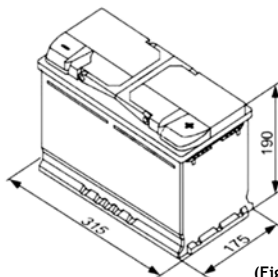

(Fig. 4 - Battery)

8.1.2 Connecting the machine

The battery charger is integrated in the machine and gives the operator maximum flexibility. For proper charging of the machine, the ambient conditions according to this operating manual must be observed. The power plug is located on top of the cover. The special charger also has an automatic shutdown as overload protection.

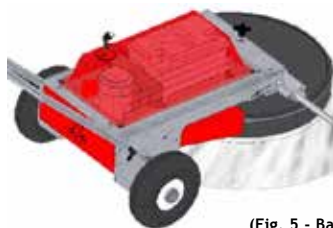

(Fig. 5 - Battery charging preparation)

9 Start-up

For start-up the hand-held sweeper is brought from the rest position to the working position.

9.1 Adjusting the handle height

To adjust the height of the handle, a handle height adjustment is provided allowing the height to be set without tools. Thus, the handle height can be easily, quickly and ergonomically adjusted for different body heights.

9.1.1 Adjustment process



(Fig. 6 - Handle height)

- ✓ Unlock locking bolts according to the diagram on both sides.
- ✓ Move the handle into the desired working position.
- ✓ Lock the latch bolt properly in the bore hole again.

9.2 Einstellen des Kehrbesens

Depending on the degree of wear of the bristles or depending on the debris, the height of the brush can be varied continuously, e.g. for long-fibered debris (hay, straw) a higher setting is required than, for example, for sand.

The brush height is adjusted via the wing nut.

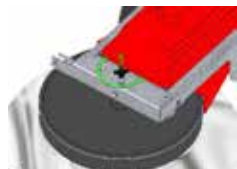

(Fig. 7 - Brush adjustment)

- ✓ Loosen the wing nut.
- ✓ Turn the adjusting knob until the desired brush height is reached. Observe the directional markings for lifting and lowering on the sweeper.
- ✓ Fix the adjusting knob by tightening the wing nut.

9.3 Starting the engine WR 870 Honda | Pro

Before starting the engine, make sure that the lever to reverse the direction of rotation is in the neutral position (as shown) and the brush is in the rest position.

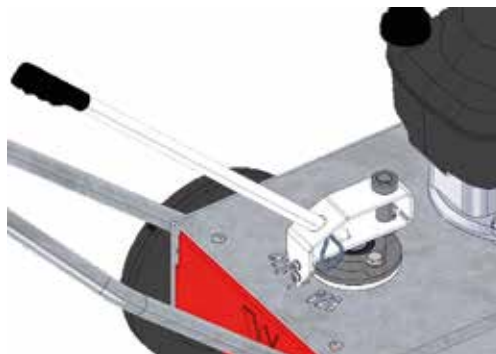

(Fig. 8 - Engine start)

9.3.1 Opening the fuel valve

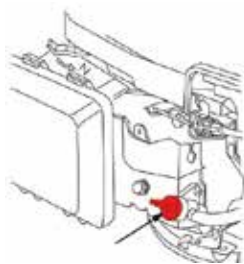

(Fig. 9 - Fuel valve)

- ✓ The fuel valve is located on the left in the direction of travel, below the fuel tank.
- ✓ Rotation to the left » Open (see also embossing on the top)

9.3.2 Cold start



(Fig. 10 - Cold start controller)

- ✓ Slide the throttle into the rearmost position (choke).
- ✓ **START**

9.3.3 Starting at operating temperature



(Fig. 11 - Operating temperature controller)

- ✓ Slide the throttle into the position slightly above idle.
- ✓ **Between MIN and MAX**

9.3.4 Starter cord



(Fig. 12 - Starter cord)

- ✓ First pull the handle of the starter cord lightly until resistance is felt: then pull hard.

NOTICE

Please let the handle of the starter cord run back slowly. This prevents damage to the engine.

9.3.5 After the cold start



(Fig. 13 - Start operating temperature)

- ✓ If the engine was started with the aid of the choke, set the throttle to the fastest or maximum position as soon as it has warmed up and is running evenly without choke. Adjust the throttle to the desired engine speed. **Optimal performance at full throt-**

9.4 Determining sweeping direction WR 870 Honda | PRO

The Radial Sweeper is equipped with a robust mechanism for reversing the direction of rotation. The desired direction of rotation is set by means of a hand lever, which can be easily reached from the normal working position.



(Fig. 14 - Determine the direction of sweeping)

Pull the lever up to remove the retaining pin from the hole. Now swing the lever into the desired position and then push the retaining pin into the provided hole.

Since the power transmission from the engine to the brush element is via a V-belt drive that requires some friction, you should press the direction selector lever in the desired direction until there is a noticeable resistance (no force necessary) and then fix it in the hole. Depending on the degree of wear of the belt, it may be necessary after a certain period of use to fix the lever in the next additional hole.

NOTICE

Before changing the direction of rotation, you should stop the brush by moving the lever to the neutral position (see above in the middle) to avoid unnecessary belt wear. Then position the lever again so that the brush element turns in the desired direction.

9.5 Stopping the engine WR 870 Honda | Pro

Move the direction selector lever to the neutral position to stop the brush element from rotating. Now slide the throttle into the position „Min“, then into the stop position.

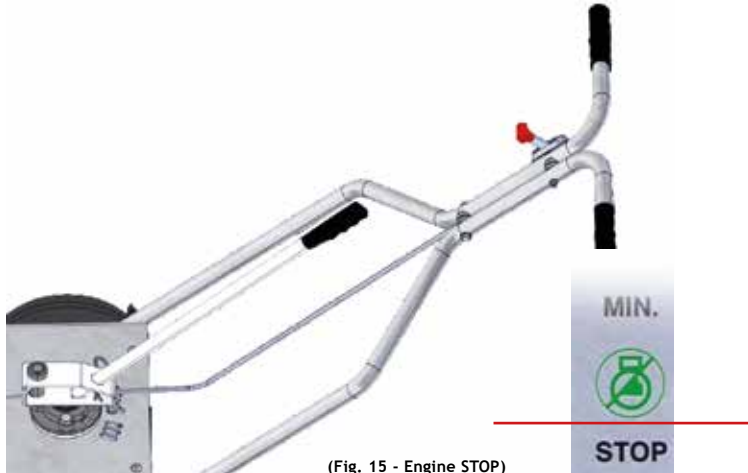

(Fig. 15 - Engine STOP)

Now close the fuel valve if you do not want to operate the brush again immediately.

9.6 Charging the WR 870 Battery

Westermann Radial Sweepers are equipped with a maintenance-free battery.

The enclosed charger plugs into a standard 220V mains socket. Then the adapter of the charger is inserted into the socket on the back of the brush.

Now the battery charges automatically!

The battery charger is equipped with overload protection, so that overcharging is prevented. The charging time depends on the battery level.

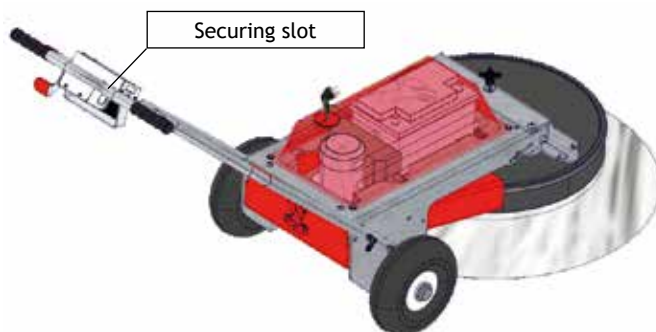

(Fig. 16 - Battery charging)

The WR 870 Battery is equipped with overcharging protection in the form of a fuse which switches off the machine before it can be damaged.

At the same time, the fuse serves as a shut-off device, since the removal of the fuse protects the sweeper from unauthorised use.

If the fuse is triggered, the sweeper must be checked for any technical errors.

9.6.1 Blown fuse

NOTICE

A blown fuse could indicate a machine defect. In this case, please contact your local dealer or have the machine checked by a specialist workshop.

9.7 Starting the WR 870 Battery | Pro

To start, the sweeper must be on a level surface to ensure proper brush startup.

Make sure that the fuse required for operation is in the slot provided.

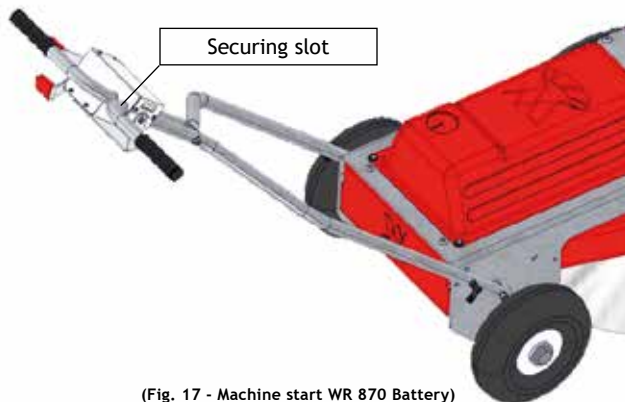

(Fig. 17 - Machine start WR 870 Battery)

A lever is mounted on the handle of the sweeper with which the direction of rotation can be selected in a comfortable way. The lever is adjusted in such a way that when the lever is released, the Radial Sweeper stops turning in the rest position.

Depending on the desired direction of rotation, the lower part of the lever is now pulled upwards by hand against the handle or the upper part of the lever is pressed by hand against the handle. By releasing the lever, the rotation is slowed down and the sweeper comes to a standstill.

10 Operation

10.1 Operation description

Start in rest position, then bring from rest position into working position

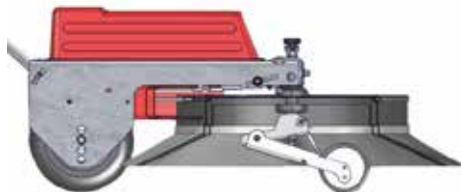

Depending on the debris and sweeping amount, a reaction force is felt on the hand-held machine, and must be countered by the operator accordingly. If the reaction force is too strong for the operator, the already formed „swath“ must be picked up. Too strong a reaction force can also be caused by a wrong set brush height. If this is the case, the brush height must be adjusted according to ch. 9.2. A sudden reaction force (kickback) can also occur when pushing with the rotating sweeping brush against a firm resistance. **Caution is needed!**

10.2 Service interval

The first 50 hours of operation have a major impact on the performance and life of the machine. The following considerations should be taken into account to ensure you enjoy your **WR 870** for a long time.

- ✓ Repeatedly inspect nuts, bolts and screws etc. and re-tighten if necessary.



Proper maintenance is of crucial importance for the operational safety of the vehicle.

11 Attachments

The following attachments can be mounted on the Westermann Radial Sweeper. This ensures a variety of uses.

Windrow maker



- The attachments themselves must not be changed!
- The safety regulations in chapter 4 apply.
- The conversion or modification of the attachments by the operator or a third person, causes liability for the resulting damage to expire.

11 Attachments

11.1 Attachment of the windrow maker



(Fig. 18 - Inserting the windrow maker)

The windrow maker is mounted on the side of the frame of the Radial Sweeper. For this purpose, the connecting rod of the swath plate is inserted slightly at an angle into the frame. The windrow maker is fixed in place using the illustrated spring pin.

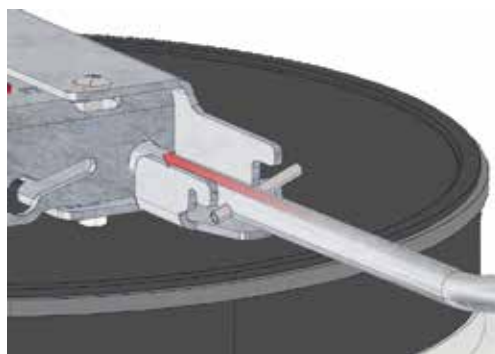

(Fig. 19 - Locking the windrow maker)

11.2 Transport position of windrow maker



(Fig. 20 - Inserting the windrow maker)

If the swath plate is not needed, it can be placed on the machine as shown.

To do this, the linkage of the swath plate is pulled out of the frame at a slight angle and then inserted into the rear slot. The swath plate then lies on the handle.

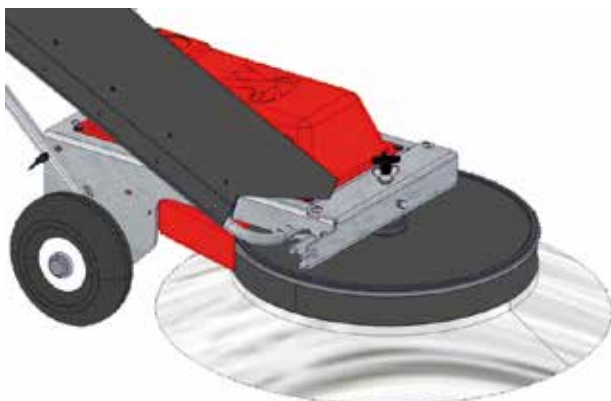

(Fig. 21 - Locking the windrow maker)

12.1 General



All maintenance, repair and modification work on the **WR 870** is only to be carried out at a standstill and with the power supply disconnected or the engine switched-off. The procedure described in the operating manual for stopping the machine must be strictly adhered to.



The **WR 870** is to be checked to ensure it is in a safe condition and secured to prevent it rolling away.



The safety regulations in chapter 4 apply.

Modification of or changes to the machine is/are only permitted after consultation with the manufacturer. Original replacement parts and manufacturer-authorized accessories are provided for safety. The use of other parts releases the manufacturer from liability for the consequences thereof.

Note before starting work:

- ✓ Check for externally visible damage and defects! Immediately report any changes (including those regarding operating behaviour) to the responsible service personnel! If necessary, take the machine out of service immediately!
- ✓ Check the completeness and functionality of all accessories. Worn parts, or those whose functionality has been impaired must be replaced. Replacement parts must be ordered from the manufacturer.
- ✓ Monitor the completeness and legibility of all type and information labels as well as the operating manual. Replace missing or illegible signs and documents.

Please note during regular maintenance:

- If necessary, electronically stored instructions for maintenance must be available in paper form during maintenance.
- For maintenance work involving components from third-party manufacturers, consult the documentation of the third-party manufacturer if necessary.
- Maintenance work requiring specialist knowledge can only be carried out by service personnel.
- The intervals specified in the maintenance schedule must be adhered to as a maximum, but they can also be shorter, depending on operator specifications and environmental conditions.
- Correct safety-relevant defects immediately!
- Only use original spare parts and manufacturer approved accessories/ tools.
- Only use components that meet the required specifications.

12.2 WR 870 Honda engine

NOTICE

Details of maintenance and care of the engine can be found in the enclosed operating instructions. It contains all necessary maintenance steps such as oil change, spark plug replacement or inspection intervals that affect the engine.

12.3 Cleaning

Clean the brushes and the jockey wheel from stuck dirt. By simply lifting the front part of the sweeper (press on the handle), the lifting device is folded into the rest position and the bristles no longer touch the ground.

12.4 Lubrication

Regular check of wheel and brush bearings for leaks. Damaged bearing units must be replaced!

12 Maintenance and servicing

12.5 Replacement of the brush element

In the case of signs of wear or defects on the brush, you have the option of replacing the brush ring with a new one. To do this please follow the following steps.

12.5.1 Removal and installation of the brush element

On the WR 870 Honda, empty the fuel tank before tipping over the brush. Then tilt the sweeper for rear access (handles on the ground for a stable grip and safe access).



! DANGER

Crushing hazard due to dropping of the Radial Sweeper!
The tilting of the Radial Sweeper can happen uncontrolled by external influences and cause hazards.

Therefore:

- ⇒ Carefully follow the steps listed below when tilting the Radial Sweeper.
- ⇒ Secure the position of the Radial Sweeper by putting additional weight on the handle.



(Fig. 22 - Replacement of the brush element)

The brushes consist of a brush ring, which is held in place by a metal clip. By loosening the metal clips, it is possible to remove the brush ring.

NOTICE

Assembly takes place in reverse order.

12.6 V-belt replacement | V-belt tightening

Loosen the two V-belt tensioning screws as shown in the figure and slide the plate towards the centre of the machine. Push the sheet in until the V-belt, which runs in the groove of the brush element, relaxes as far as possible.

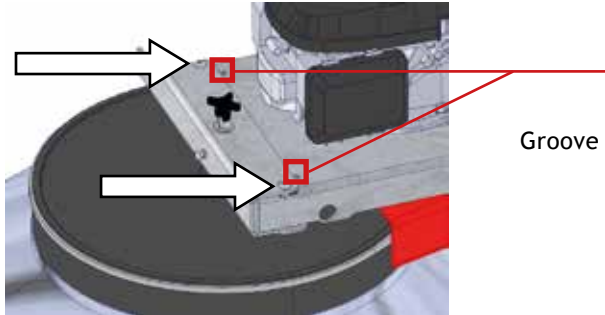

(Fig. 23 - Belt tensioning screws)

Now lever the V-belt from bottom to top out of the groove (possibly with the help of a screwdriver). Turn the brush element so that the V-belt slides completely up out of the groove.

BezDrive belt label: SPZ 2137

Please only use original fabric V-belts from the authorised dealer!

The assembly takes place in reverse order.

The V-belt tensioning screw must now be adjusted again so that optimum power transmission from the engine to the brush element is ensured. The tensioning of the V-belt takes place with the help of appropriate tools (e.g. screwdriver), which can be inserted into the above-mentioned grooves, in order to achieve the force required to tension the V-belt via the lever action.

NOTICE

Please make sure that the plate and the tensioning screws are not over tightened, otherwise the bearing of the engine or brush could be damaged.

If you can push in the V-belt about 20mm with two fingers, the tension is sufficient to transfer the force.

12 Maintenance and servicing

12.6.1 Replacement of change-of-direction belt WR 870 Honda

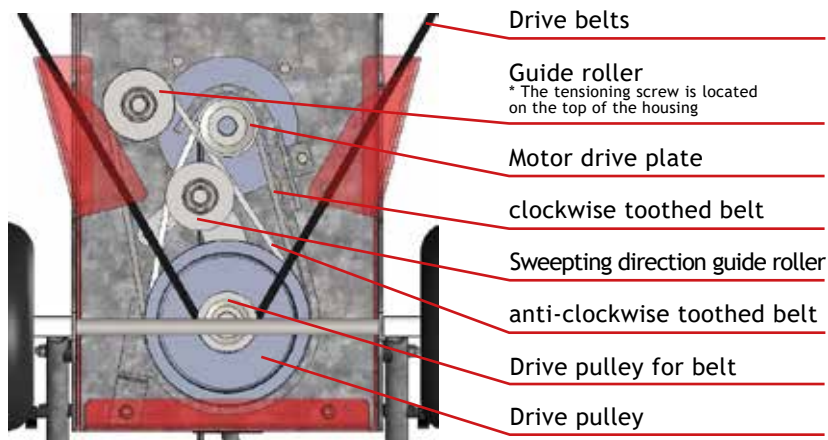

(Fig. 24 - Replacing the direction change belt)

12.6.2 The clockwise V-belt / toothed belt (internal combustion engine only)

If necessary, loosen the tensioning screw on the top of the housing of the V-belt / timing belt, so that you can lever out the toothed belt from the groove of the drive disc. Now it can be replaced with a new toothed belt.

Drive belt label: Ax38/X13x965Li

Please only use original toothed belts from authorised dealers!

Make sure that the V-belt / toothed belt runs with its teeth outwards over the guide roller and the drive pulley. The toothed side should engage in the groove of the motor drive pulley. When adjusting the tension, please use the tensioning screw on the top of the housing.

NOTICE

The toothed belt may only be stretched so far that power transmission only occurs when the lever to change the direction of rotation is pulled and the connected sweeping direction guide roller is affected.

In the neutral position of the guide roller, the V-belt / timing belt should be able to slide over the guide roller and drive pulley.

12.6.3 The V-belt rotating clockwise (only internal combustion engine)

Dismantling takes place after removal of the anti-clockwise V-belt / toothed belt. After disassembling the above-mentioned belt, remove the two screws of the belt guide plate.

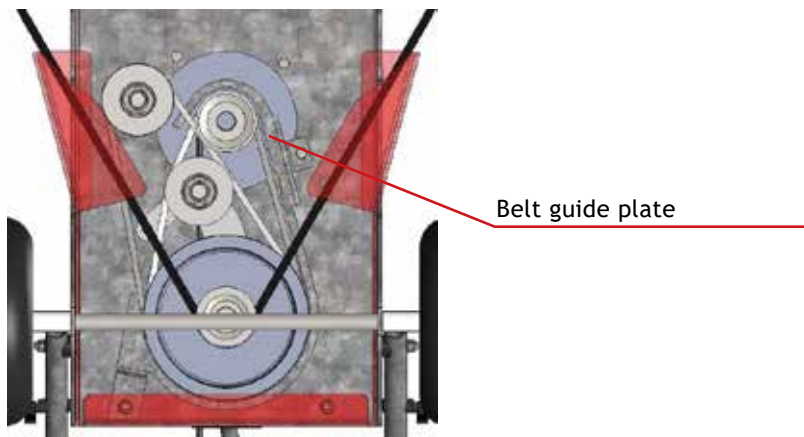

(Fig. 25 - Replacement clockwise belt)

Then you can pry the V-belt from the engine drive pulley and the drive pulley and replace it with a new V-belt. Install the new V-belt in the groove of the engine drive pulley and drive pulley in reverse order.

Finally, mount the belt guide plate, the anti-clockwise V-belt / toothed belt and the drive belt according to the technical specifications in this operating manual.

12 Maintenance and servicing

12.7 Screw connections

Check bolts and nuts for the first time after five hours of operation and then tighten them regularly (every 50 hours of operation).

- All torques MA are standard values for metric standard threads according to DIN. Friction coefficient 0.14 - new bolts - unlubricated. The values were recommended as guide values by different bolt manufacturers. We cannot assume liability for use.
- Self-locking nuts must be replaced after each dismantling.



Torque MA						
Thread	3.6	5.6	6.8	8.8	10.9	12.9
M6	3.43	4.51	8.73	10.3	14.71	17.65
M8	8.24	10.79	21.57	25.50	35.30	42.17
M10	16.67	21.57	42.17	50.01	70.61	85.32
M12	28.44	38.25	73.55	87.28	122.58	147.10
M14	45.11	60.80	116.70	135.27	194.17	235.36
M16	69.63	93.16	178.46	210.84	299.10	357.94
M18	95.13	127.40	245.17	289.30	411.88	490.34
M20	135.33	180.44	348.14	411.88	576.50	669.26
M22	162.40	245.17	470.72	558.98	784.45	941.44

12.8 Fuse replacement

The machine is protected by a fuse. The fuse slot on the WR 870 Battery is located on the handle in the switch housing.

60 Ampere fuse



(Fig. 26 - Fuse)

12 Maintenance and servicing

12.9 Procedures after maintenance

After completing the maintenance, perform the following steps:

- Make sure that all previously loosened screw connections are tightened.
- Ensure all previously removed guards and covers are properly reinstalled.
- Ensure all tools, materials, and other equipment used have been removed from the work area.
- Clean work area and remove cleaning material such as cloths, etc.
- Make sure all safety devices are working properly.

12.10 Notes regarding maintenance work

NOTICE

For maintenance work and related replacement of components, only the use of original spare parts is permitted.

12.11 Documentary list

NOTICE

Incidents and interference must be recorded in a documentary list. The documentary lists must be stored electronically and/or in paper form.



Electrical hazards



Risk of injury due to electrical voltage!
Defective or improperly attached battery pole caps can lead to hazards due to electrical voltage in the event of damage.

Therefore:

- ✓ Operation may only be carried out by trained personnel.
- ✓ Perform all operating steps in accordance with the instructions in this operating manual.
- ✓ Before operation, make sure all battery terminals are properly connected and undamaged.
- ✓ Use the provided personal protection equipment!



Hot surfaces



Risk of injury due to hot surfaces!
Parts and components of the machine may become very hot in the event of excessive use and may result in injury if they come into direct contact with the skin.

Therefore:

- ✓ Operation may only be carried out by trained personnel.
- ✓ Perform all operating steps in accordance with the instructions in this operating manual.
- ✓ Mark affected components with warning signs.



Improper operation

DANGER

Risk of injury due to improper operation!
Improper operation can lead to personal injury or property damage.

Therefore:

- ✓ Operation may only be carried out by trained personnel.
- ✓ Perform all operating steps in accordance with the instructions in this operating manual.
- ✓ Before operation, make sure all fasteners are properly connected and undamaged.
- ✓ Pay attention to order and cleanliness! Loosely stacked or objects lying around, such as tools, cables and components are potential sources of accidents.



Operation movements

DANGER

Risk of injury due to moving components!
During operation, individual components or components of the machine can move and lead to dangerous situations.

Therefore:

- ✓ Always monitor the danger zone during operation and ensure that no persons are present there.
- ✓ Switch off the equipment before carrying out work on the main switch and secure it against being switched on again.
- ✓ Perform all operating steps in accordance with the instructions in the operating manual.
- ✓ Do not operate the machine without safety devices. Install all safety devices securely before starting.



Machine recoil

DANGER

Risk of injury due to unpredictable machine movements!
Unpredictable machine movements could lead to personal injury or property damage.

Therefore:

- ✓ Operation may only be carried out by trained personnel.
- ✓ Perform all operating steps in accordance with the instructions in this operating manual.
- ✓ Sweepings and the volume thereof must be taken into account.
- ✓ Check brush height.
- ✓ Avoid collisions with solid objects.

14 Storage conditions

Park the Westermann WR 870 in a dry and clean place and secure against unplanned start-up.

NOTICE

The machine **MUST**, after **EVERY** use be properly connected to the charging station again to prevent a deep discharge of the battery.



(Fig. 27 - T-handle switch)

Risk of accident!



The radial sweeper is to be checked to ensure it is in a safe condition and secured to prevent it rolling away.

- Park the machine level in its resting position.



(Fig. 28 - Rest position)

NOTICE

Check vehicle for possible damage! Clean the WR 870 thoroughly, if necessary. Dirt attracts moisture and leads to corrosion. Repair paint damage if necessary.



(Fig. 29 - WR 870)

15 Cleaning

For cleaning, the following points must be observed.



- Cleaning with water or high-pressure cleaner is not permitted.
- Cleaning may only be carried out with compressed air or with other aids such as hand brushes.

Dirt attracts moisture and leads to rusting.

16 Troubleshooting

16.1 WR 870 Honda | PRO

Fault	Cause	Remedy
Engine will not start	<ul style="list-style-type: none"> • Engine malfunction • Direction selector lever not in neutral position 	<ul style="list-style-type: none"> • Refer to troubleshooting in the engine manual • Move the direction selector lever to the neutral position
brush does not terurn correctly	<ul style="list-style-type: none"> • Wrong sweeping height • Loose screw connections 	<ul style="list-style-type: none"> • Adjust the sweeping height to the conditions • Check screws and tighten if necessary
Brush does not turn or stops at low resistance	<ul style="list-style-type: none"> • V-belt defective • Toothed belt defective • Drive belt pretension insufficient • Direction of rotation change lever not in the correct position 	<ul style="list-style-type: none"> • Check V-belt; replace if necessary • Tighten the drive belt • Move the direction selector lever to a drive position
Brush does not despite moving director change lever	<ul style="list-style-type: none"> • V-belt defective • Toothed belt defective • Drive belt pretension insufficient • Timing belt pretension insufficient (lever can be pushed beyond the intended holes) 	<ul style="list-style-type: none"> • Check V-belt; replace if necessary • Tighten the drive belt tensioning bolt • Adjust the toothed belt tensioning device

16 Troubleshooting

16.2 WR 870 Akku | PRO

Fault	Cause	Remedy
Motor will not start	<ul style="list-style-type: none">• Flat battery• Fuse defective• Pole terminals connection fault• Oxidation at pole terminals	<ul style="list-style-type: none">• Charge the battery• Replace fuse.• Tighten pole terminal screws• Clean with pol-grease if necessary
Battery is not charging	<ul style="list-style-type: none">• Oxidation at the mains plug or charger• Overload protection triggered by the charger	<ul style="list-style-type: none">• Clean contact• Switch on the overload protection on the charger
Abnormal noises, ratting or similar	<ul style="list-style-type: none">• Loose screws on the device	<ul style="list-style-type: none">• Check screw connections retighten if necessary.
Brush does not return correctly	<ul style="list-style-type: none">• Wrong sweeping height	<ul style="list-style-type: none">• Adjust the sweeping height to the conditions.
Brush does not turn or stops at low resistance	<ul style="list-style-type: none">• V-belt defective• V-belt tension insufficient	<ul style="list-style-type: none">• Check V-belt; replace if necessary• Tension the V-belt.

17.1 Decommissioning

After finishing operation, the must WR 870 be stored properly: When storing the machine, the following points must be observed:

- The WR 870 must be placed in such a way that it cannot tip over or fall.
- At the storage site, the ambient conditions must meet the required conditions (see technical data).
- The machine, which does not have sufficient protection itself, must be protected against the effects of the weather and corrosive substances if these can impair safety.

If the machine is to be shut down for a long time, it may be necessary to take preservation measures to prevent corrosion and other damage.

17.2 Dismantling / Disposal

Disassembly/disposal should be carried out by a specialist. Using specialists in the recycling and waste management sectors ensures that waste is disposed of correctly and recycled. The existing raw materials of the Radial Sweeper must be sorted according to disposal type and material. The copper-containing components such as cables can be recycled. Equipment such as fuses, batteries, capacitors, regulators, etc. must be disposed of as electronic waste, these must not be disposed of with household waste in order to prevent environmental damage. The support frame and the protective covers can be recycled as metal scrap.

The following policy for the Westermann warranty is valid as of 01.01.2002.

1. When using Westermann products in the consumer goods sector (private use), which were sold through Westermann dealers, the warranty period from the date of sale to the end customer is 2 years.
When using Westermann products in the capital goods sector (commercial/professional), which were sold through Westermann dealers, the warranty period from the date of sale to the end customer is 1 year.
2. The warranty covers defects that can be attributed to material and/or manufacturer errors. Any faults resulting from a Westermann product defect or production defect during the warranty period will be recognized and remedied by repair or replacement of parts via a Westermann dealer.
3. Exempted from this are wear parts such as Bowden cables, starter cord, V-belts, bearings, clutch plates, tires, air filters, spark plugs, glow plugs, fuel filters, oil filters, sweeping brushes, rubber lips, batteries as long as these do not exhibit obvious material defects.
4. Warranty claims are generally excluded in case of poor maintenance and care. Regular maintenance and cleaning of the product according to the instructions in the Westermann operating manual is imperative. Damage due to improperly performed maintenance and cleaning work cannot be accepted as a valid guarantee claim.
5. The operating instructions for the respective product as well as safety instructions must be observed. Damage caused by operating errors, improper use or use of accessories not approved by Westermann GmbH & Co. KG cannot be accepted as a valid warranty claim.
6. It must be ensured that only original Westermann spare parts and Westermann accessories are used, which can be obtained from the Westermann dealer. If original Westermann spare parts or Westermann accessories are not used, consequential damage and increased risk of accidents cannot be ruled out. These consequential damages are not covered by the warranty.

18 Warranty policy

7. From 01.01.2002 only the Westermann warranty claim process is to be used. The warranty claim information is mandatory. Exceptions cannot be made. Warranty claims without the required information cannot be processed and will be returned for completion of the missing information.
8. The Westermann Machine and Warranty certificate (warranty document) is to be completed within 4 weeks of the date of sale of the product, including the data of the end customer, the end customer's signature as well as the indication of use (private | commercial | professional) to Westermann customer service.
9. The warranty period for original Westermann spare parts is 2 years if the installation is certified by a Westermann dealer (for wear parts the restriction under point 3 applies). For warranty claims relating to replacement parts or warranty repairs, we ask you to keep the parts in question for 2 months after receipt of the warranty claim. We will, if necessary, request the relevant part for examination.
10. The ordering of required spare parts for warranty purposes can only be made via Westermann customer service for logistical reasons as of 01.01.2002. From Monday to Friday between 08:00 and 16:30 telephone orders can be placed. Please state the item number, the serial number of the device in question and your customer no. Our telephone no. is: +49 (0) 5931 / 49690-0. In addition, there is the possibility to fax us your order for warranty replacement parts. Our fax no. is: +49 (0) 5931 / 49690-99.
11. Should your warranty claim be rejected, the ordered spare parts will be charged to you at their usual purchase conditions. Invoicing also occurs if no warranty claim has been received by Westermann Customer Service within 4 weeks. If a Westermann spare part for warranty repairs is not available at short notice (within 2 working days) and you use an original Westermann spare part from your stock to repair the damage, a free replacement delivery will be made by us when available or deliverable by Westermann customer service. If a replacement part is no longer available, the purchase price paid by you will be refunded.
12. The defective parts or machines are to be sent the Westermann factory in Meppen. Upon acceptance of the warranty, the freight charges will be reimbursed.

18 Warranty policy

13. The warranty claim must be submitted to Westermann customer service no later than 5 working days after the repair has been completed, in order to ensure fast processing. Warranty claims received 3 months after the repair cannot be processed.
14. All previous warranty policies as well as the conditions in the General Terms and Conditions and point 7 hereby become invalid.

A handwritten signature in blue ink, appearing to read 'Alwin Westermann', is written over a horizontal line.

Westermann GmbH & Co. KG

19 Spare parts list

19.1 WR 870 Honda | PRO

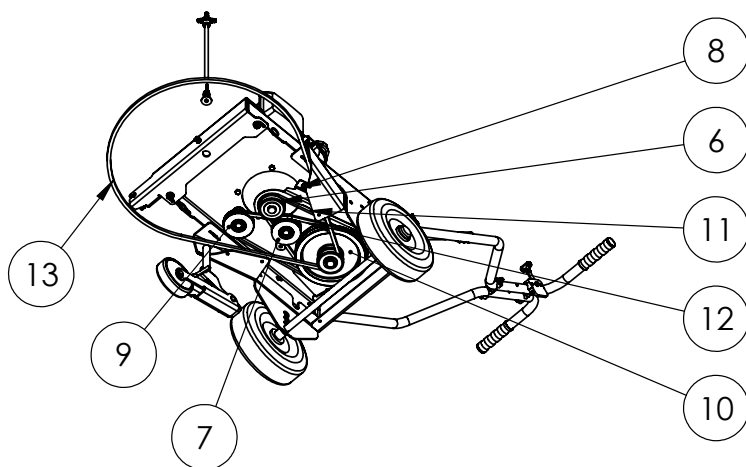
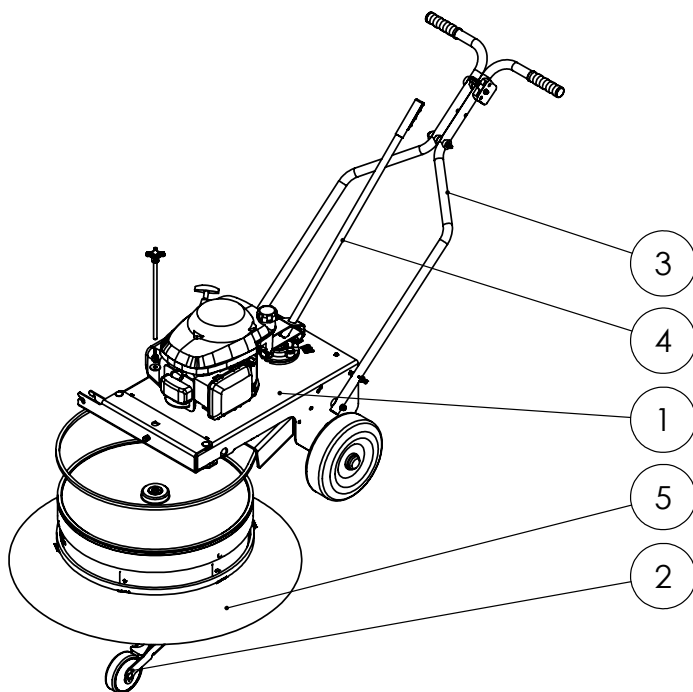

19 Spare parts list

19.1 WR 870 Honda | PRO

POS-NR.	Artikel	BENENNUNG	part name	MENGE/ quantity
1	s.u.	Grundrahmen WR	baseframe WR	1
2	VMBG-00-00083/84 VMBG-00-00081/84 (Pro)	Aufstellbock WR 870 mit Spindel Aufstellbock WR 870 Pro mit Spindel	support wheel with spindle WR870 support wheel with spindle W870 Pro	1
3	VMBG-00-00082	Schiebeholm WR 870 Honda	push handle WR 870 Honda	1
4	s.u.	Verstellhebel gesamt	control lever	1
5	s.u.	Bürste WR 870 / Pro	brush WR 870 / Pro	1
6	DR-00-00191 (Motor GXV) DR-00-00073 (Motor GCV)	Riemenscheibe (Motorantriebsscheibe)	v-belt pulley for engine	1
7	s.u.	Umlenkrolle	guide pulley	1
8	LA-00-00571	Flachstahl Riemenschutz	v-belt cover	1
9	s.u.	Spannrolle	tensioner	1
10	s.u.	Antriebswelle komplett	drive shaft assembly	1
11	KT-00-00431	B2058 Keilriemen (13x900 Blau)	B2058 v-belt (13x900 blue)	1
12	KT-00-00432	B2059 Keilriemen (13x1000)	B2059 v-belt (13x1000)	1
13	KT-00-00430	AB1017 (Keilriemen SPZ 2137)	AB1017 v-belt SPZ 2137	1

Luftfilter / airfilter

Artikel	Benennung	part name
KT-00-00376	Luftfilter GCV160 / GCVx170	air filter GCV160/GCVx170
KT-00-00374	Luftfilter GXV 160	air filter GXV 160

19.2 Base frame WR 870 Honda | PRO

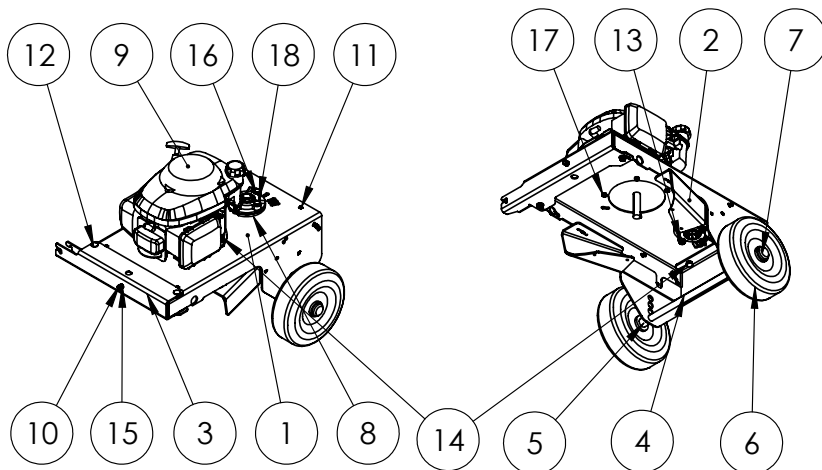

POS-NR.	Artikel	BENENNUNG	part name	MENGE/ quantity
1	LA-00-00569	Motorblech WR 870 Honda	engine plate WR 870	1
2	PE-00-00030	Untergestell WR 870 rot	subframe WR 870 red	1
3	LA-00-00563	Aufnahme Stützrad WR 870	support wheel retainer WR870	1
4	DR-00-00054	Radachse	wheel axle	1
5	KT-00-00889	Distanzstück d20xD28xh25	spacer d20xD25xh25	2
6	RE-00-00007	Luftrad 260 x 85	air wheel 260x85	2
7	KT-00-00186	Radkappe 20er RAL 9011	hub cap 20mm RAL 9011	2
8	LA-00-00570	Hufeisen WR 870 Honda	distance plate WR870	1
9		Motor Honda (Modellabhängig)	engine (depending on model)	1
10	DIN-933-M8x35	Sechskantschraube M8x35 DIN 933	hexagon head screw M8x35	1
11	DIN-603-M8x20	Flachrundschraube M8x20	mushroom head square neck bolt M8x20	2
12	DIN-603-M10x80	Flachrundschraube M10x80	mushroom head square neck bolt M10x80	2
13	DIN-SZ-M10	Sperrzahnmutter M10	lock nut M10	5
14	DIN-SZ-M8	Sperrzahnmutter M8	lock nut M8	6
15	DIN-439-M8	Sechskantmutter M8 flache Ausführung	nut M8 flat design	1
16	DIN-933-M12x65	Sechskantschraube M12 x 65	hexagon head screw M12x65	3
17	DIN-933-M8x40	Sechskantschraube M8 x 40	hexagon head screw M8x40	4
18	KT-00-00234	Lager UCFC 205 bearbeitet	bearing UCFC 205 machined	2

19.3 Support wheel with spindle WR 870 Honda | PRO

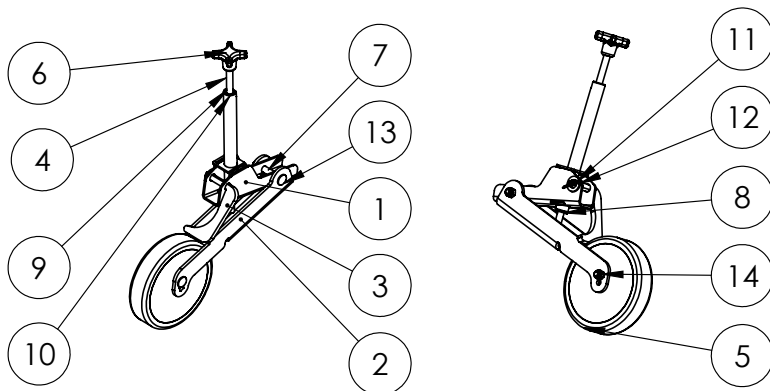

POS-NR.	Artikel	BENENNUNG	part name	MENGE/ quantity
1	SB-00-00065	SBG Drehstütze WR 870	rotating support WR 870	1
2	LA-00-00567	Radhalter	wheel holder	1
3	LA-00-00566	Klinke WR 870	latch WR 870	1
4	DR-00-00076	Einstellbolzen Gewindestange M10 290mm	adjustment bolt threaded rod M10 290mm	1
5	RE-00-00010 RE-00-00013	Vollgummirad 125 Vollgummirad 160 (Pro)	solid rubber wheel 125mm solid rubber wheel 160mm (Pro)	1
6	KT-00-00123	Kreuzgriff Form K Stahlbuchse M10	star handle M10	1
7	DR-00-00138	Distanzhülse ϕ 10x37,5	spacer ϕ 10x37,5	1
8	KT-00-00096	Blindnietmutter M10 / 12x19mm	blind rivet nut M10 / 12x19mm	1
9	DIN-315-M10	Flügelmutter M10 DIN 315	winged nut M10	1
10	DIN-9021-10,5	Kotflügelscheibe 10.5 groß	fender washer 10,5	1
11	DIN-94-2,5x20	Splint 2,5x20	splint pin 2,5x20	1
12	DIN-125-13	Scheibe 13,0	washer 13,0	1
13	DIN-603-M8x60	Flachrundschraube M8x60	mushroom head square neck bolt M8x60	2
14	DIN-985-M8	Sechskantmutter M8 selbstsichernd	hexagon nut M8 self locking	2

19.4 Push handle WR 870 Honda | PRO

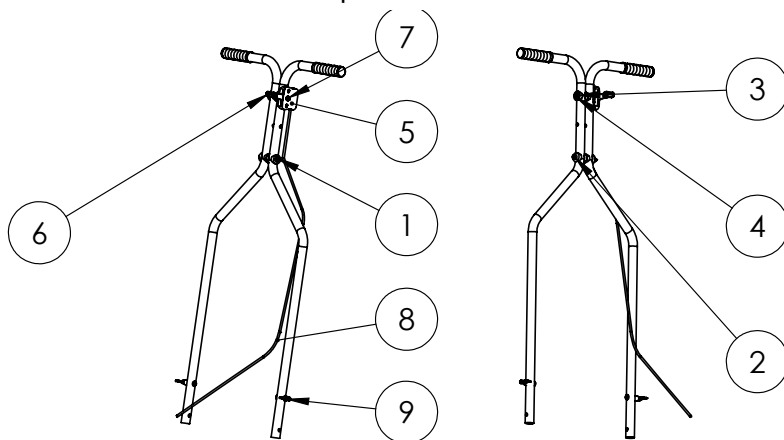

POS-NR.	Artikel	BENENNUNG	part name	MENGE
1	DIN-985-M8	Sechskantmutter M8 selbsts.	sqare nut M8 self locking	1
2	DIN-912-M8x80	Zylinderschraube M8x80	cylinder head screw M8x80	1
3	DIN-9021-6,4	Kotflügelscheibe 6,4	fender washer 6,4	1
4	DIN-931-M6x80	Sechskantschraube M6x80	sqare head screw M6x80	1
5	KT-00-00438	Gehäuse Bowdenzug	bowden cable housing	1
6	KT-00-00434	Knauf rot	knob red	1
7	DIN-985-M6	Sechskantmutter M6 selbsts.	hexagon nut M6 self locking	1
8	KT-00-00515	Bowdenzug für Radialbesen und CM2 (1320mm)	bowden cable 1320mm	1
9	KT-00-00793	Rastriegel GN912.8-8-M16x1,5-A	locking pin M16x1,5	

KT-00-00192	Bowdenzug komplett (enthält Pos.5,6 und 8)	bowden cable assembly (contains pos.5,6 and 8)	1
-------------	--	--	---

19.5 Control lever WR 870 Honda | PRO

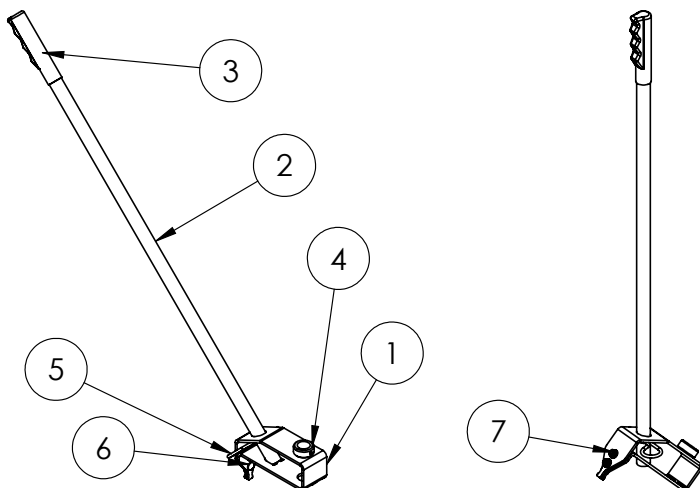

POS-NR.	Artikel	BENENNUNG	part name	MENGE
1	LA-00-00572	Verstellblech WR 870	adjustment plate WR 870	1
2	DR-00-00133	Verstellgriff WR 870 Honda	adjustment handle WR 870	1
3	KT-00-00193	Muldengriff schwarz	recessed handle black	1
4	KT-00-00167	Stellingring A20	adjustment ring A20	1
5	KT-00-00243	Federstecker doppelt 3mm	lockpin 3mm	1
6	DIN-603-M6x16	Flachrundsraube M6x16	mushroom head square neck bolt M6x16	2
7	DIN-SZ-M6	Sperrzahnmutter M6	locking nut M6	2

19.6 Guide pulley WR 870 Honda | PRO

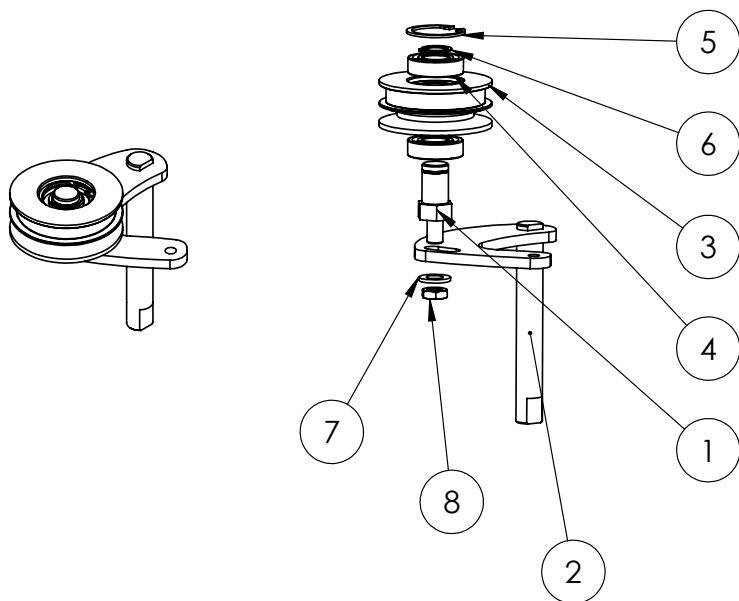

POS-NR.	Artikel	BENENNUNG	part name	MENGE
1	DR-00-00126	Achse Umlenkung	axle for guide pulley	1
2	SB-00-00066	SBG Hebel Umlenkung	lever for guide	1
3	DR-00-00129	Riemenscheibe 2 rillig	v-belt pulley 2 flutes	1
4	KT-00-00538	Rillenkugellager DIN 625 - 6004	grooved ball bearing 6004	2
5	DIN-472-J42	Sicherungsring DIN 472 - 42 x 1.75	circlip DIN 472-42x1,75	1
6	DIN-471-A20	Sicherungsring DIN 471 - 20 x 1.2	circlip DIN 471-20x1,2	1
7	DIN-125-A13	Scheibe DIN 125 - A 13	washer DIN 125 - A 13	1
8	DIN-934-M12	Sechskantmutter M12	hexagon nut M12	1

19 Spare parts list

19.7 Tensioner WR 870 Honda | PRO

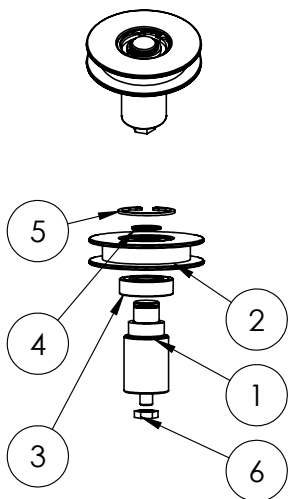

POS-NR.	Artikel	BENENNUNG	MENGE
1	DR-00-00139	Achse Excenter Spannrolle	1
2	DR-00-00128	Keilriemenscheibe (Spannrolle)	1
3	KT-00-00538	Rillenkugellager DIN 625 - 6004	1
4	DIN-471-A20	Circlip DIN 471 - 20 x 1.2	1
5	DIN-472-J42	Circlip DIN 472 - 42 x 1.75	1
6	DIN-439-M10	Sechskantmutter M10 niedrige Form	1

19.8 Drive shaft assembly WR 870 Honda | PRO

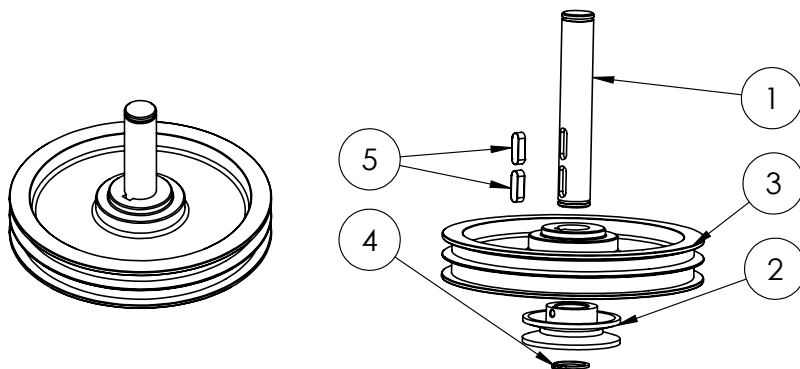

POS-NR.	Artikel	BENENNUNG	part name	MENGE/ quantity
1	DR-00-00125	Antriebswelle WR870	drive shaft WR 870	1
2	DR-00-00130	Keilriemenscheibe SPA13	v-belt pulley SPA 13	1
3	DR-00-00131	Keilriemenscheibe (gr. doppelt)	v-belt pulley (large. double)	1
4	DIN-471-AS-25	Sicherungsring DIN 471 25x2	circlip DIN 471 25x2	1
5	DIN-6885-8x7x25	Passfeder 8 x 7 x 25 DIN 6885	parallel key 8x7x25 DIN 6885	2

19 Spare parts list

19.9 Brush WR 870 Honda | PRO

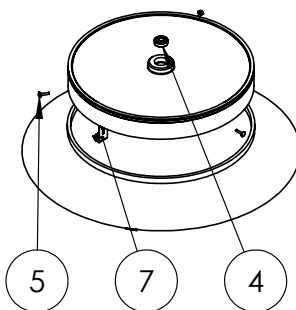
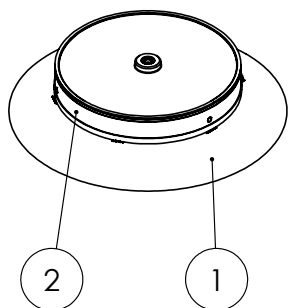
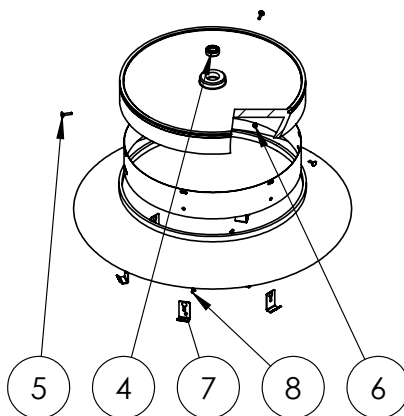
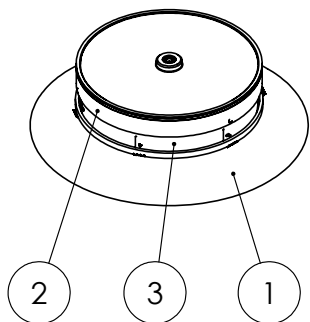

19 Spare parts list

19.9 Brush WR 870 Honda | PRO

POS-NR.	Artikel	BENENNUNG	part name	MENGE
1	KT-00-00304 KT-00-00452 KT-00-00475	Bürstenring Ø870 (PPN) Bürstenring Ø870 (Draht) Bürstenring Ø870 (Draht/PPN)	brush ring Ø870 (PPN) brush ring Ø870 (wire) brush ring Ø870 (wire/PPN)	1
2	KT-00-00303	Bürstentopf für Ø870	brush pot Ø870	1
3	LA-00-00352	*Blechring WR870 Pro	*sheet metal ring WR 870 Pro	1
4	KT-00-00538	Kugellager 6004 2RS	ball bearing 6004 2RS	2
5	DIN-603-M6x25	Flachrundsraube M6x25	mushroom head square neck bolt M6x25	6(*3)
6	DIN-SZ-M6	Sperrzahnmutter M6	lock nut M6	6(*3)
7	LA-00-00542	Bürstenring Klammer	brush ring clip	6
8	DIN-7380-M6x12	*Linsenschraube M6x12	*pan head screw M6x12	6

* Nur bei Pro

* only for Pro

19 Spare parts list

19.10 WR 870 Akku|PRO

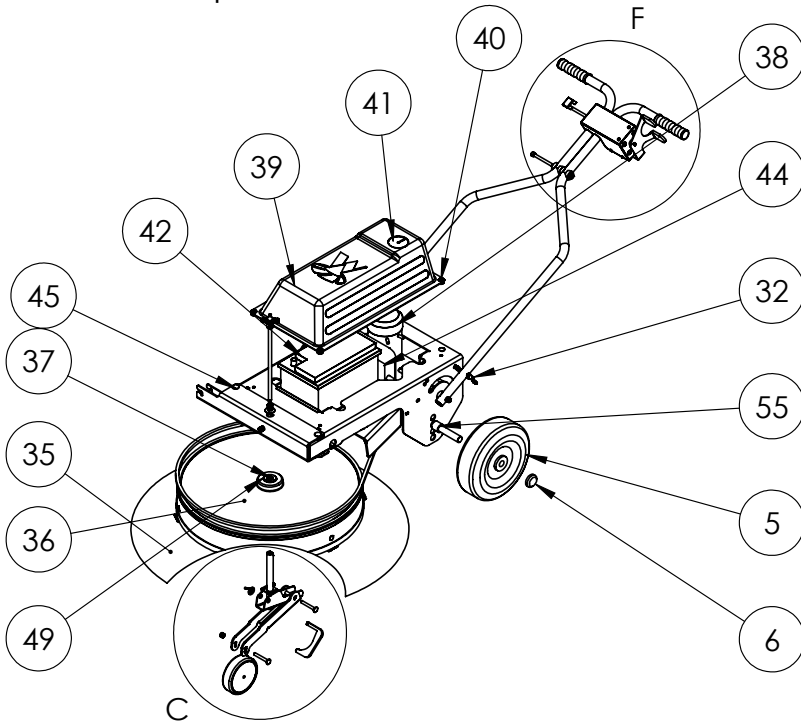

19.10 WR 870 Akku|PRO

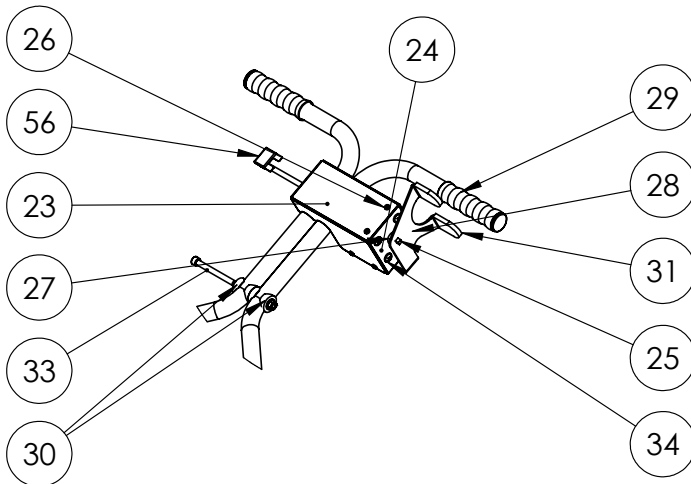

19.10 WR 870 Akku | PRO

POS-NR.	Artikel	BENENNUNG	part name	MENGE/ quantity
1	LA-00-00557	Grundrahmen	base frame	1
2	LA-00-00558	Motorkonsole	engine bracket	1
3	PE-00-00030	Untergestell WR 870 rot	lower frame WR 870 red	1
4	DR-00-00054	Radachse	wheel axle	1
5	RE-00-00007	Lufrad 260 x 85	air wheel 260x85	2
6	KT-00-00186	Radkappe 20er RAL 9011	hub cap 20mm RAL 9011	2
7	KT-00-00084	Kantenschutzprofil 1-4mm	edge guard 1-4mm	1
8	DIN-603-M8x20	Flachrundschraube M8x20	mushroom head square neck bolt M8x20	6
9	DIN-SZ-M8	Sperrzahnmutter M8	locking nut M8	6
10	SB-00-00065	SBG_Drehstütze WR 870	rotary support WR870	1
11	LA-00-00567	Radhalter WR870 t=5mm S355	wheel retainer WR870 t=5mm S355	1
12	LA-00-00566	Klinke WR870 t=8mm	latch WR 870 t=8mm	1
13	DR-00-00076	Einstellbolzen Gewindestange M10 l=290mm	threaded rod for adjustment M10 l=290mm	1
14	RE-00-00010 RE-00-00013	Vollgummirad 125er Vollgummirad 160er (Pro)	solid rubber wheel 125mm solid rubber wheel 160mm (Pro)	1
15	KT-00-00123	Kreuzgriff	star handle	1
16	DR-00-00138	Distanzhülse \varnothing 10x37,5	spacer \varnothing 10x37,5	1
17	DIN-315-M10	Flügelmutter M10	wing nut M10	1
18	DIN-9021-10,5	Kotflügelscheibe 10.5	fender washer 10,5	1
19	DIN-94-3,2x20	Splint 3.2x20	splint pin 3,2x20	1
20	DIN-125-13	Scheibe 13,0 DIN 125	washer 13,0 DIN 125	1
21	DIN-985-M8	Sechskantmutter M8 selbtsichernd	selflocking hexagon nut M8	2
22	DR-00-00123	Griffrohr WR 870 \varnothing 26,9x2,3 S235JR galv. verz.	handle tube WR 870 \varnothing 26,9x2,3 galvanized	2
23	LA-00-00559	Halteblech Schalter WR870 Akku	retaining plate switch WR 870	1
24	LA-00-00561	Deckel WR870 Akku	cover WR 870	1
25	KS-00-00029	Schalter CA 50	switch CA 50	1
26	DIN-7500-M4x8	Gewindefurchende Schraube M4x8	thread grooving screw M4x8	8
27	KT-00-00495	Distanzstück 10,5x30,0x8,0 Polyamid 6, natur	spacer 10,5x30x8 Polyamid 6 natural	1
28	LA-00-00560	Wahlschalter WR870 EN- AW5754	mode switch WR 870 EN-AW5754	1
29	KT-00-01001	Handgriff 24er	handle 24mm	2
30	KT-00-00227	Sattelscheibe 3/4" Rohr C=8,3 A=27-29	saddle plate 3/4" pipe	8
31	KT-00-00242	Flachkappe PVC rot 30x3mm 45mm lang	flat cover PVC red 30x3x45mm	2
32	KT-00-00793	Rastriegel GN912.8-8-M16x1,5-A	locking pin M16x1,5	2
33	DIN-912-M8x80	Zylinderschraube M8x80 8.8	cylinder head screw M8x80 8.8	2

19.11 Support wheel WR 870 Akku | PRO

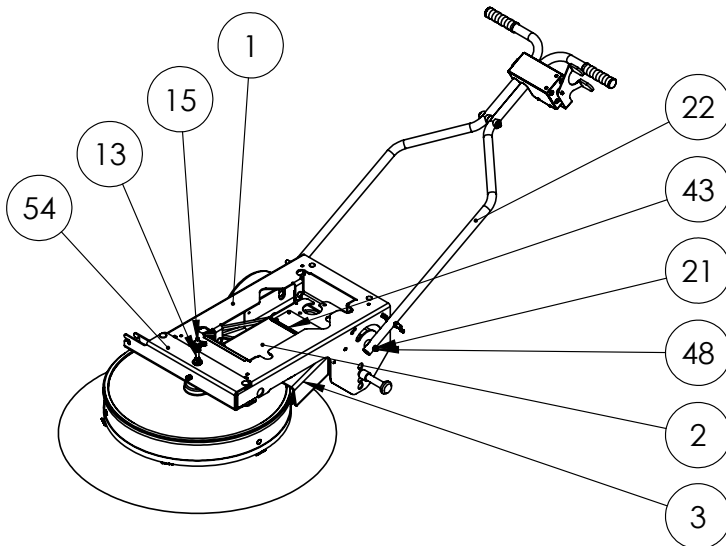
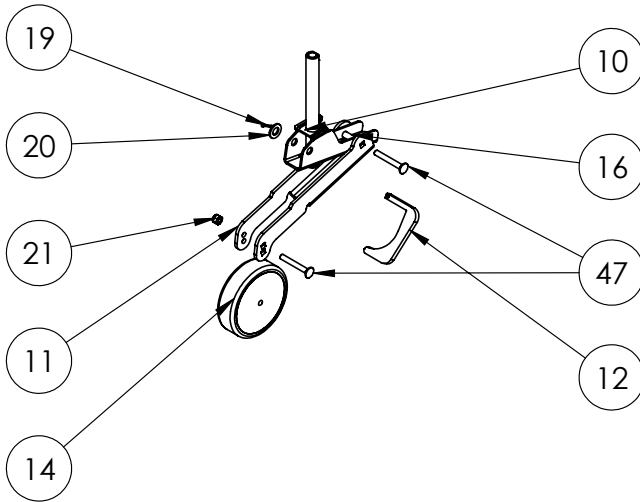

19.11 Support wheel WR 870 Akku | PRO

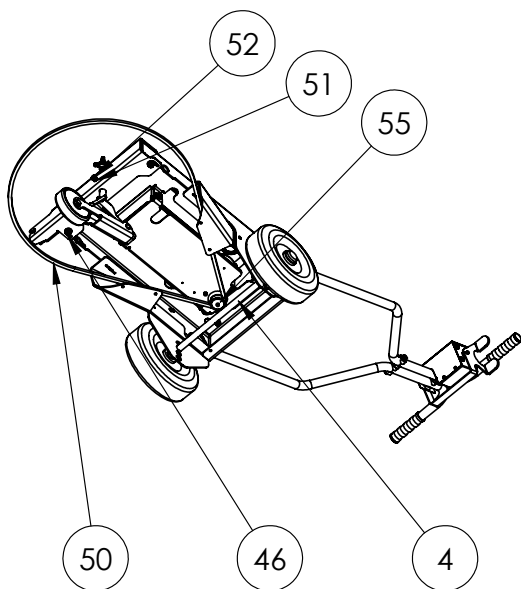
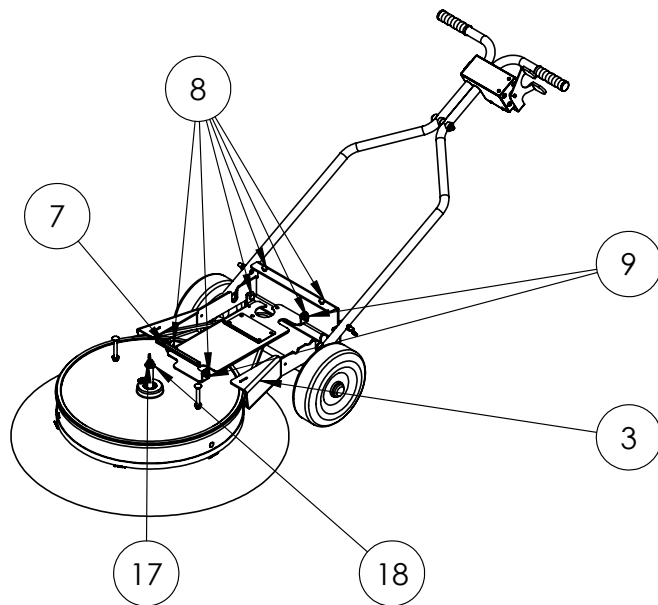

19 Spare parts list

19.11 Support wheel WR 870 Akku | PRO

34	DIN-7981-4,8-13	Blechschraube 4,8x13 galv. verz.	sheet metal screw	4
35	KT-00-00304	Bürstenring Ø870mm (PPN)	brush ring Ø870 (PPN)	1
36	KT-00-00303	Bürstentopf für Ø870mm Bürste	brush pot for Ø870mm brushes	1
37	KT-00-00538	Kugellager 6004 2RS 42x20x12	ball bearing 6004 2RS 42x20x12	2
38	MO-00-00007	Gleichstrommotor 500W 12V	dc motor 500W 12V	1
39	PE-00-00028	Haube WR870 Akku rot 550x310x115	hood WR 870 Akku red 550x310x115	1
40	KT-00-00499	Schraubnieten A=7, B=3-9mm (schwarz)	plastic screw pins A=7 B=3-9mm	4
41	PE-00-00029	Durchfallsicherung WR 870 Akku RAL 3000	drop safeguard WR 870 RAL 3000	1
42	KS-00-00025	Batterie naß 12V 66 Ah	battery 12V 66Ah	1
43	LA-00-00589	Batteriehalteblech WR870 t=2mm	battery holding plate t=2mm	1
44	KS-00-00093	Ladegerät ohne Ladestecker für WR 5Ah 12V	battery charger 5Ah 12V	1
45	DIN-603-M10x80	Flachrundschraube M10x80	mushroom head square neck bolt M10x80	2
46	DIN-SZ-M10	Sperrzahnmutter M10 DIN 6923	locking nut M10 DIN 6923	2
47	DIN-603-M8x60	Flachrundschraube M8x60	mushroom head square neck bolt M10x60	2
48	DIN-603-M8x45	Flachrundschraube M8x45	mushroom head square neck bolt M10x45	2
49	DIN-988-20x28x1,5	Passscheibe 20x28x1,5 Stahl	shim 20x28x1,5	1
50	KT-00-00430	Keilriemen SPZ 2137	v-belt SPZ 2137	1
51	DIN-SZ-M8	Sperrzahnmutter M8 DIN 6923	locking nut M8 DIN 6923	1
52	DIN-933-M8x35	Sechskantschraube M8x35 8.8	hexagon square screw M8x35 8.8	1
53	LA-00-00563	Aufnahme Stützrad WR 870	wheel support WR 870	1
54	DR-00-00090	Motorriemenscheibe DC Motor	belt pulley dc motor	1
55	KT-00-00889	Distanzstück d20xD28xh25	spacer d20xD28xh25	2
56	KS-00-00014	60 A Flachsicherung	fuse 60 A	1

19.12 Brush 870 Akku | PRO

Brush 870 Akku / brush

Brush 870 Akku PRO / brush

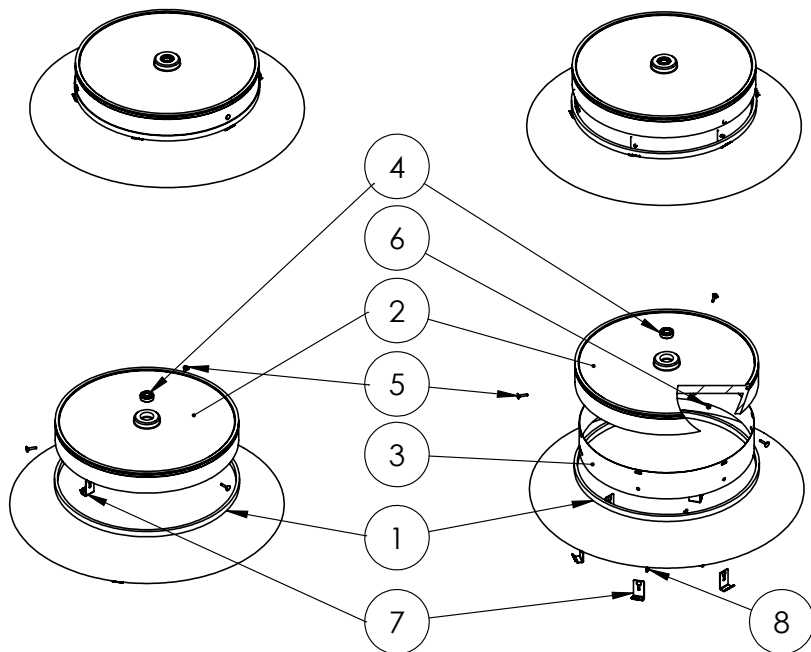

POS-NR.	Artikel	Benennung	part number	MENGE/ quantity
1	KT-00-00304	Bürstenring (PPN)	brush ring (PPN)	1
2	KT-00-00303	Bürstentopf	brush pot	1
3	LA-00-00352	*Blechring WR870 Pro	sheet metal ring WR 870 Pro	1
4	KT-00-00538	Kugellager 6004 2RS	ball bearing 6004 2RS	2
5	DIN-603-M6x25	Flachrundschraube M6x25	mushroom head square neck bolt M6x25	6(*3)
6	DIN-SZ-M6	Sperrzahnmutter M6 DIN 6923	locking nut M6 DIN 6923	6(*3)
7	LA-00-00542	Bürstenring Klammer	brush ring clip	6
8	DIN-7380-M6x12	*Linsenschraube M6x12	pan head screw M6x12	6

* Nur bei Pro
*only for Pro

20 Plans and other information

20 Plans and other information

20.1 Current-flow plan

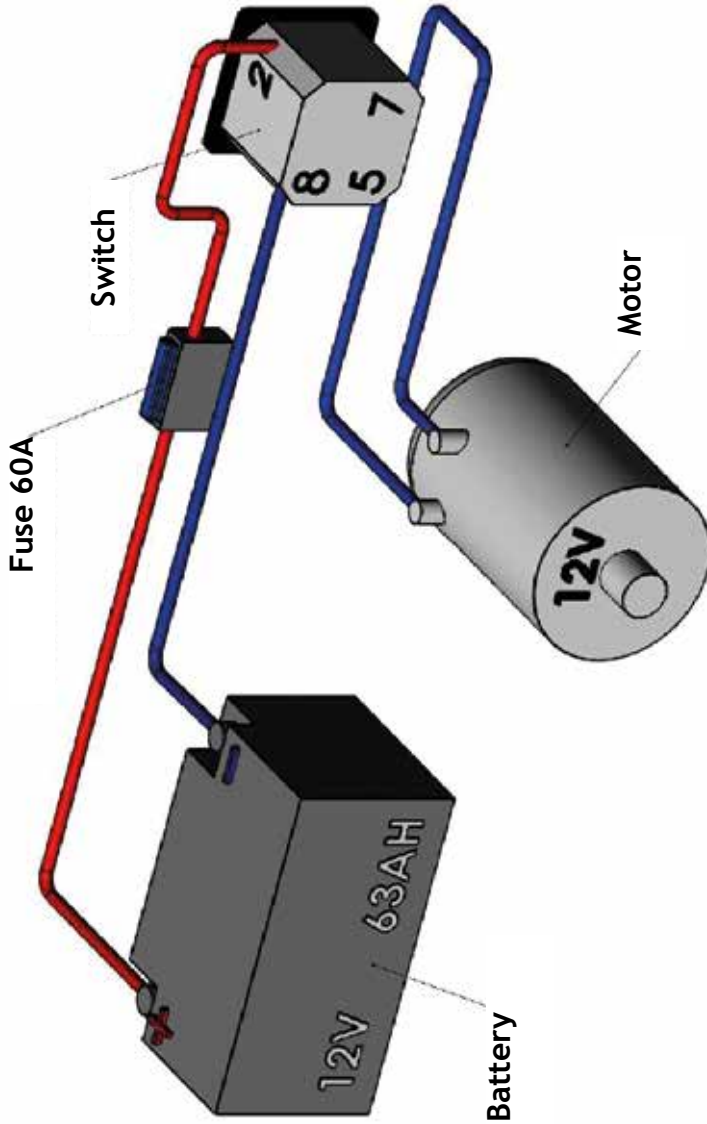

21 List of figures

Fig. 1	- Danger area.....	15
Fig. 2	- Dimensions.....	23
Fig. 3	- Technical data.....	24
Fig. 4	- Batterie	27
Fig. 5	- Battery charging preparation	27
Fig. 6	- Handle height	28
Fig. 7	- Brush adjustment	28
Fig. 8	- Engine start.....	29
Fig. 9	- Fuel valve	29
Fig. 10	- Cold start controller.....	30
Fig. 11	- Operating temperature control.....	30
Fig. 12	- Starter cord.....	30
Fig. 13	- Start operating temperature.....	30
Fig. 14	- Determine the direction of sweeping.....	31
Fig. 15	- Engine STOP	32
Fig. 16	- Battery charging	33
Fig. 17	- Machine start WR 870 Akku.....	34
Fig. 18	- Inserting windrow maker	37
Fig. 19	- Lock the windrow maker	37
Fig. 20	- Inserting windrow maker	38
Fig. 21	- Lock the windrow maker	38
Fig. 22	- Replacement of the brush element	41
Fig. 23	- Belt tensioning	42
Fig. 24	- Replacing the direction change belt.....	43
Fig. 25	- Replacement clockwise-belt	44
Fig. 26	- Fuse.....	45
Fig. 27	- T-handle switch	50
Fig. 28	- Rest position.....	50
Fig. 29	- WR 870	50



Westermann GmbH & Co. KG
Schützenhof 23
D-49716 Meppen

Telefon: +49 (0) 59 31 / 4 96 90-0

Internet: www.westermann-radialbesen.de

E-Mail: info@westermann-radialbesen.de

Your expert dealer